

MONROE

BRAKES

INSTALLATION TIPS

Quick Tips for installing brake pads

Your customer expects quiet, clean, dependable, and safe brakes. The following reminders will help get the best results and minimize comebacks.

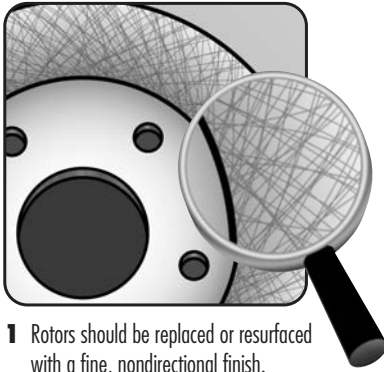

1 Rotors should be replaced or resurfaced with a fine, nondirectional finish.



2 Wash rotor with non-detergent (clear) liquid cleanser and warm water.



3 Do not touch, or contaminate friction material.



4 Lubricate sliding surfaces and back of pad with brake lubricant.

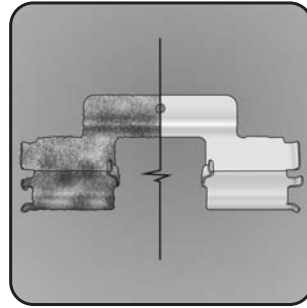

5 Inspect all components. Replace worn hardware, including pad installation clips.



6 Open bleeder and then compress piston. Do not hammer to set pads in place.

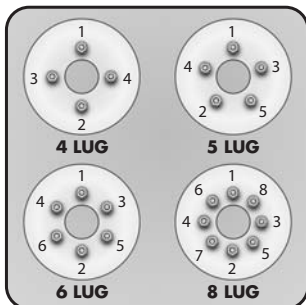

7 Torque lug nuts using star pattern.

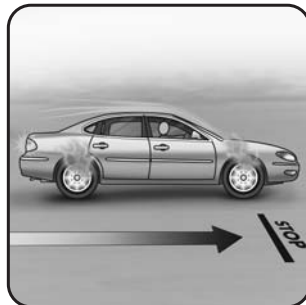

8 High-speed break-in is NOT required or recommended. Follow manufacturer's recommendation.



9 Check temperature of all four brakes to ensure balanced braking effort.

